

CASH VALVES CRYOGENIC VALVES AND CONTROLS

A broad range of pressure build regulators, pressure reducing valves, final line gas valves and combination pressure build economizer valves for cryogenic service



FEATURES

- Six models for pressure reducing or pressure build-up service.
- Five models for back-pressure service on economizer circuit.
- Three models for combined pressure building and economizer functions.
- Low temperature cut-off valves.
- Two models for final line gas service.
- High purity regulating valves for pressure reducing, back pressure and differential services.
- All parts commercially cleaned for cryogenic/oxygen service or high purity gas compatibility.
- Complementary 'Y' pattern strainers reduce maintenance costs.
- Cryogenic safety and shut-off valves also available.

GENERAL APPLICATION

A variety of controls for cryogenic systems including liquid and gas line-pressure build-up regulators, economizer (heat leak) back pressure valves, temperature safety valves, combination valves, shut-off valves and final-line/service-line regulators.

TECHNICAL DATA

Materials:	Bronze, brass and stainless steel
Sizes:	1/4" to 2" (7 to 50 mm)
Connections:	Threaded NPTF (BSP optional on some models)
Max initial pressure:	650 psi (45.7 kg/cm ²)
Temperature ranges	
Standard range:	+150° to -320°F (339 to 78K)
High purity valves:	+400° to -425°F (478 to 19K)

CASH VALVES CRYOGENIC VALVES AND CONTROLS

LIQUID-GAS DISTRIBUTION SYSTEM SCHEMATIC DIAGRAM

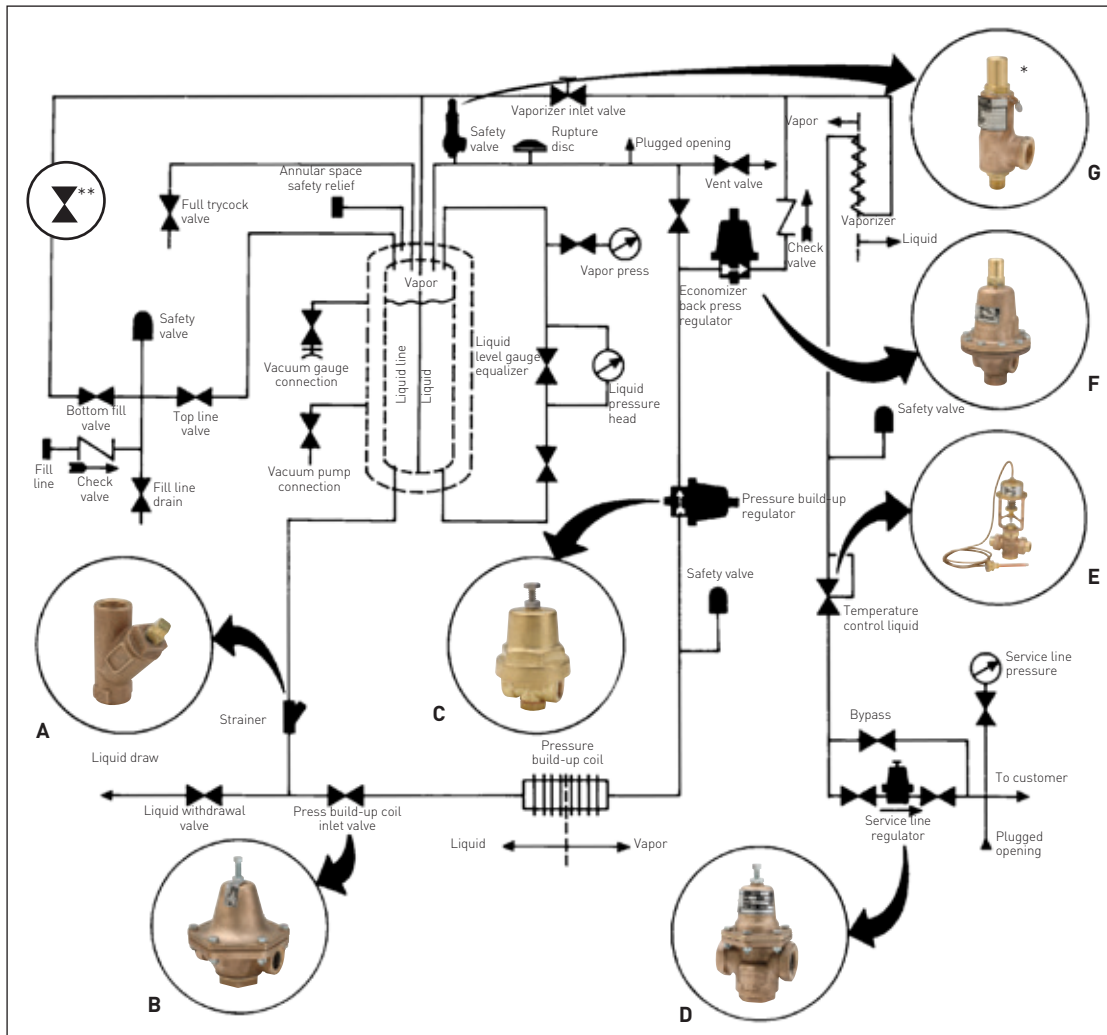

- A. Type SY-70C
- B. Type B
- C. Type A-32
- D. Type E-55
- E. Type LTC
- F. Type FR
- G. Type C-776

* C-776 cryogenic safety relief valve - for additional information, write or call for data sheet VCTDS-00515.

** Shut-off valve - for additional information, see page 17.

OVERVIEW

Cryogenics - the science of materials at extremely low temperatures - has become increasingly important to industry. One important aspect of this field is the liquification of normally gaseous elements which are used widely throughout the industry, including:

- Oxygen - used extensively in BOF furnaces in the steel industry, for metal cutting, as a rocket fuel and in medicine.
 - Acetylene - widely used in welding.
 - Nitrogen - used in refrigeration systems, for metal degassing, in aerosol packaging and in cryogenic surgery.
 - Hydrogen - used as a rocket propellant and in the production of several metals.
 - Argon - widely used in incandescent lamps and fluorescent tubes.
 - Helium - used for arc welding, in the manufacture of electron tubes and in cryogenic research.
 - Carbon Dioxide - used in refrigeration, to make aerosol tanks and in fire fighting.
- Other cryogenic fluids include liquefied natural gas, fluorine, krypton, neon, methane and ethane.

The extensive range of Cash valves and controls is suitable for use in all the major areas of cryogenic converters, or 'dewars', which are either stationary or installed in over-the-road transport vehicles.

CASH VALVES CRYOGENIC VALVES AND CONTROLS

THE PRESSURE BUILD-UP CIRCUIT

The build-up circuit in the converter maintains a pressure of approximately 25 psi (1.76 kg/cm²) above that required to drive the liquid to the final vaporizer and a pressure differential of approximately 25 psi (1.76 kg/cm²) or higher across the service line regulator. To do this, liquid is drawn into the pressure build-up coil, where it is warmed by ambient air and vaporized. The gas then passes through the pressure build-up regulator and into the top of the tank, where it begins to build up pressure because expansion is limited by the fixed volume.

When this pressure reaches the pressure build-up regulator's set point, the regulator shuts off, stopping vaporization and pressure build-up. As liquid is forced from the tank to the final vaporizer, pressure in the tank begins to drop and the pressure build-up regulator returns to operation.

The pressure build-up regulator may be located in the liquid line before the pressure build-up coil. As it is now used for liquid rather than gas service, it may have a smaller orifice or be a smaller-sized valve. Its operation is the same as that of a gas regulator with the exception that it regulates the liquid flow before the pressure build-up coil rather than the gas flow after the coil. When pressure in the tank drops, the liquid pressure build-up regulator opens, allowing liquid to flow through the pressure build-up coil and vaporize.

Pressure build-up regulators are available for most cryogenic system applications. The Type A-32 is a small 1/4" (8 mm) pressure build-up valve; the larger Type B, Type G-60 and Type E-55 can be used for either liquid or gas.

The Type B is available in sizes from 1/4" to 2" (8 mm to 50 mm), the G-60 from 1/4" to 1 1/2" (8 mm to 40 mm) and the Type E-55 from 1 1/4" to 2" (32 mm to 50 mm).

A-32 PRESSURE REDUCING OR PRESSURE BUILD-UP SERVICE

Construction

Brass forged body and spring chamber; bronze trim and diaphragms; PTFE seat disc and diaphragm gasket; stainless steel pressure spring. All parts are commercially cleaned for cryogenic service.

Note: also available in stainless steel and special construction for hi-purity service. Contact your sales representative.

Temperature rating: +150°F to -320°F (339K to 78K)

Maximum initial pressure: 600 psi (42.18 kg/cm²)

REDUCED PRESSURE RANGES

Maximum working pressure	
psi	(kg/sq cm)
2-25	(0.14-1.76)
15-65	(1.05-4.57)
40-100	(2.81-7.03)
50-150	(3.52-10.55)
75-175	(5.27-12.30)
100-250	(7.03-17.58)
200-400	(14.06-28.12)
300-600	(21.09-42.18)



DIMENSIONS

Size	Dimensions						Shipping weight		
	A		B		C				
inches	(mm)	inches	(mm)	inches	(mm)	inches	(mm)	lbs	(kgs)
1/4	(8)	2 1/4	(57.15)	3 3/16	(80.96)	5/8	(15.88)	1 1/8	(0.51)
3/8	(10)	2 1/4	(57.15)	3 3/16	(80.96)	5/8	(15.88)	1 1/8	(0.51)

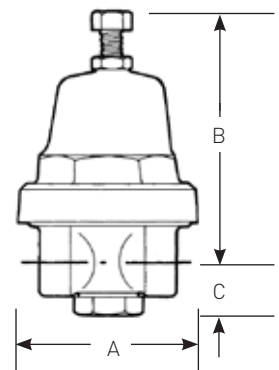

CASH VALVES CRYOGENIC VALVES AND CONTROLS

A-36 PRESSURE REDUCING OR PRESSURE BUILD-UP SERVICE

Construction

Brass forged body and bronze spring chamber; bronze trim and diaphragms; PTFE seat disc and gaskets; stainless steel pressure spring. All parts are commercially cleaned for cryogenic service.

Note: also available in stainless steel and special construction for hi-purity service. Contact your sales representative.

Temperature rating: +150°F to -320°F (339K to 78K)
 Maximum initial pressure: 600 psi (42.18 kg/cm²)

REDUCED PRESSURE RANGES

Maximum working ranges	
psi	(kg/sq cm)
10-30	(0.70-2.11)
20-50	(1.41-3.52)
40-80	(2.81-5.62)
75-150	(5.27-10.55)
100-250	(7.03-17.58)
High pressure construction only	
200-400	14.06-28.12

DIMENSIONS

Size		Dimensions						Shipping weight	
		A		B		C			
inches	(mm)	inches	(mm)	inches	(mm)	inches	(mm)	lbs	(kgs)
3/8	(10)	27/16	(61.91)	4 1/2	(114.30)	1	(25.40)	2 1/2	(1.13)
3/8	(10)	27/16	(61.91)	4 1/2	(114.30)	1	(25.40)	2 1/2	(1.13)

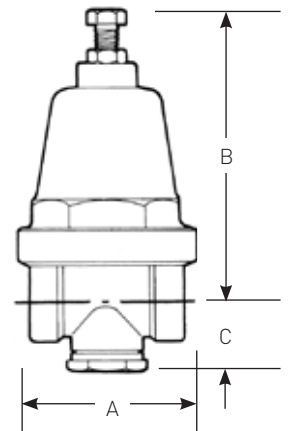

A-401 PRESSURE REDUCING OR PRESSURE BUILD-UP SERVICE

Construction

Bronze cast body and bronze spring chamber; bronze trim and neoprene/nylon diaphragms; FKM seat disc and gaskets; stainless steel pressure spring. All parts are commercially cleaned for cryogenic service.

Temperature rating: +150°F to -320°F (339K to 78K)
 Maximum initial pressure: 600 psi (42.18 kg/cm²)

REDUCED PRESSURE RANGES

Maximum working ranges	
psi	(kg/sq cm)
20 to 60	(1.41 to 4.22)
40 to 80	(2.81 to 5.62)
75 to 125	(5.27 to 8.79)
100 to 250	(7.03 to 17.58)
200 to 400	(14.06 to 28.12)
High pressure construction only	
300 to 600	(21.09 to 42.18)

DIMENSIONS

Size		Dimensions						Shipping weight	
		A		B		C			
inches	(mm)	inches	(mm)	inches	(mm)	inches	(mm)	lbs	(kgs)
1/2	(15)	4	(101.6)	4.64	(117.80)	1.95	(49.6)	4 1/2	(1.68)

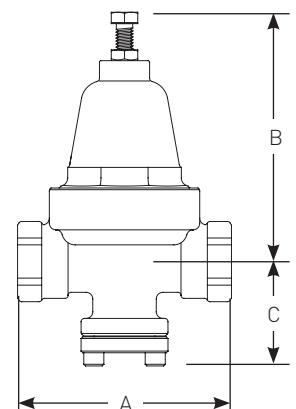

CASH VALVES CRYOGENIC VALVES AND CONTROLS

MODELS A36, A401 SELECTION GUIDE

Example:	A36Z	B	C	S	Z	S	Z	T	H	01	-	E	0015
Model													
A36Z A36 (Bronze body)													
A36G A36 (SST body)													
A401 A401													
Size													
B 3/8" (A36)													
C 1/2" (A401)													
Service													
C Cryogenic													
F Final line gas (A401)													
Body/connection style													
S Side inlet/side outlet - straight thru NPT													
B Side inlet/side outlet - straight thru BSPT													
Spring chamber material													
Z Bronze spring chamber													
Spring chamber style													
S Standard													
V Vented													
Diaphragm material													
G 316 SST (A36)													
T Neoprene w/PTFE liner (A401 final line only)													
Z Bronze													
Seat material													
T PTFE													
V FKM (A401 final line only)													
Pressure screw style													
H Hex													
Variations													
01 Standard													
Design revision													
(-) Original design													
Spring material													
E Stainless steel													
Set pressure													
0005 5 psi													
0015 15 psi													
0100 100 psi													

Standard spring ranges - must specify during order process							
A 36 (**)	10-30	20-50	40-80	75-150	100-250	200-400	300-600
A401 (**)	20-60	40-80	75-125	100-250	200-400	300-600	

Note: (**) Stainless steel

CASH VALVES CRYOGENIC VALVES AND CONTROLS

B PRESSURE REDUCING OR PRESSURE BUILD-UP SERVICE

Construction

Bronze body, spring chamber, trim and diaphragms; PTFE seat and diaphragm gasket; stainless steel pressure spring; stainless steel bolts and nuts; PTFE bottom-plug gasket; Monel® strainer screen. All parts are commercially cleaned for cryogenic service. Also available with BSP threads.

Temperature rating: +150°F to -320°F (339K to 78K)
 Maximum initial pressure: 400 psi (28.12 kg/cm²)

Note: Type B95 available in stainless steel construction ½" thru 1" (15 to 25 mm) size.

REDUCED PRESSURE RANGES

Valve size		Maximum working ranges	
Inches	(mm)	psi	(kg/sq cm)
¼	(8)	10-30	(0.70-2.11)
		25-100	(1.76-7.03)
		50-200	(3.52-14.06)
		100-250	(7.03-17.58)
⅜	(10)	10-50	(0.70-3.52)
		40-150	(2.81-10.55)
		100-250	(7.03-17.58)
½	(15)	10-30	(0.70-2.11)
		20-75	(1.41-5.27)
		25-125	(1.76-8.79)
		100-200	(7.03-14.06)
		150-250	(10.55-17.58)
¾	(20)	10-30	(0.70-2.11)
		20-70	(1.41-4.92)
		30-100	(2.11-7.03)
		50-150	(3.52-10.55)
		100-225	(7.03-15.82)
		150-250	(10.55-17.58)
1	(25)	10-35	(0.70-2.46)
		20-60	(1.41-4.22)
		50-100	(2.52-7.03)
		100-250	(7.03-17.58)
1¼	(32)	10-30	(0.70-2.11)
		20-40	(1.41-2.81)
		35-80	(2.46-5.62)
		75-150	(3.52-10.55)
1½	(40)	10-30	(0.70-2.11)
		20-40	(1.41-2.81)
		35-80	(2.46-5.62)
		75-150	(3.52-10.55)
2	(50)	5-20	(0.35-1.41)
		10-50	(0.70-3.52)
		20-100	(1.41-7.03)

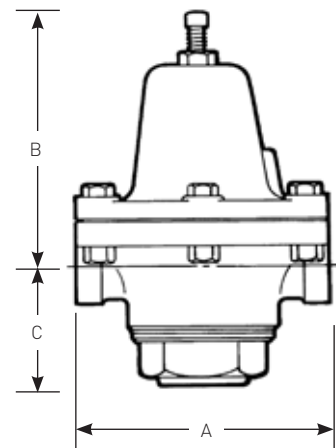

DIMENSIONS

Size		Dimensions						Shipping weight	
inches	(mm)	A		B		C		lbs	(kgs)
		inches	(mm)	inches	(mm)	inches	(mm)		
¼	(8)	3	(76.2)	2⅞	(73.03)	1¼	(44.45)	3	(1.35)
⅜	(10)	3⅞	(98.43)	4⅞	(104.78)	1¼	(44.45)	5½	(2.47)
½	(15)	4½	(114.3)	4½	(114.3)	2⅞	(53.98)	8	(3.6)
¾	(20)	5⅞	(130.18)	4⅞	(117.48)	2⅞	(53.98)	10	(4.5)
1	(25)	5⅞	(149.23)	5⅞	(136.53)	2⅞	(66.68)	16	(7.2)
1¼	(32)	6¾	(171.45)	6⅞	(155.58)	2⅞	(66.68)	20	(9.0)
1½	(40)	6¾	(171.45)	6⅞	(155.58)	3¼	(82.55)	20	(9.0)
2	(50)	9¼	(234.95)	8½	(215.9)	3½	(88.90)	37	(16.65)

CASH VALVES CRYOGENIC VALVES AND CONTROLS

TYPE B SELECTION GUIDE

Example	B	Z	A	C	S	S	Z	T	S	01	-	E	0025
Model													
B B valve													
Material of construction													
Z Bronze													
Valve size													
A 1/4"													
B 3/8"													
C 1/2"													
D 3/4"													
E 1"													
F 1 1/4"													
G 1 1/2"													
H 2"													
Service													
C Cryogenic													
F Final line gas (O ₂ clean adder required)													
Body style/connection style													
S Side inlet/side outlet - straight thru w/NPT connections													
B Side inlet/side outlet - straight thru w/BSPT connections													
C Side inlet/side outlet - straight thru w/copper tube connections (3/8" only)													
Spring chamber style													
S Standard													
D w/pressure screw cap and differential connection													
Diaphragm material													
B NBR (final line)													
Z Bronze (cryo)													
Seat material													
B NBR (final line)													
T PTFE (cryo)													
Pressure screw style													
S Standard													
Variation													
01 Standard													
Design revision													
(-) Indicates original design													
Spring material													
D Steel (final line gas)													
E SST (cryo)													
Set pressure													
0005 5 psig													
0025 25 psig													
0150 150 psig													

Standard spring ranges - must specify during order process						
B 1/4" (**)	10-30	25-100	50-200	100-250		
B 3/8" (**)	10-50	40-150	100-250			
B 1/2" (**)	10-30	20-75	25-125	100-200	150-250	
B 3/4" (**)	10-30	20-70	30-100	50-150	100-225	150-250
B 1" (**)	10-35	20-60	50-100	50-150	100-250	
B 1 1/4" & 1 1/2" (**)	10-30	20-40	35-80	75-150		
B 2" (**)	5-20	10-50	20-100			
Final line only						
B 1/4" (*)	2-25	20-60	30-100	50-150		
B 3/8" (*)	2-30	20-70	40-110	90-150		
B 1/2" (*)	2-30	10-50	30-125	50-150		
B 3/4" (*)	2-20	10-35	30-75	50-110	105-150	
B 1" (*)	2-20	10-45	20-60	55-100	90-150	
B 1 1/4" & 1 1/2" (*)	2-15	10-30	20-50	45-100	90-150	
B 2" (*)	2-20	10-60	20-100	90-150		

Note: (**) Stainless steel (*) Steel

CASH VALVES CRYOGENIC VALVES AND CONTROLS

TYPE B95 SELECTION GUIDE

Example:	B95	G	C	C	S	S	G	T	S	01	-	E	0025
Model													
B95	B95 valve												
Material of construction													
G	316 SST body and chamber												
Valve size													
C	½"												
D	¾"												
E	1"												
Service													
C	Cryogenic												
Body style/connection style													
S	Side inlet/side outlet - straight thru w/NPT connections												
Spring chamber style													
S	Standard												
K	w/pressure screw cap and differential connection												
Diaphragm material													
G	316 SST (cryo)												
Seat material													
T	PTFE (cryo)												
Pressure screw style													
S	Standard												
Variation													
01	Standard												
Design revision													
(-)	Indicates original design												
Spring material													
E	Stainless steel												
Set pressure													
0005	5 psig												
0025	25 psig												
0150	150 psig												

Standard spring ranges - must specify during order process

B95 ½" (**)	10-30	20-75	25-125	100-200	150-250	250-400	200-600
B95 ¾" (**)	10-30	20-70	30-100	50-150	100-225	150-250	
B95 1" (**)	10-35	20-60	50-100	50-150	100-250	200-400	

Note: (**) Stainless steel

CASH VALVES CRYOGENIC VALVES AND CONTROLS

G-60 PRESSURE REDUCING OR PRESSURE BUILD-UP SERVICE

Construction

Threaded ends; bronze body, spring chamber, diaphragms and trim; stainless steel pressure spring and body seat; PTFE seat and gaskets; stainless steel bolts. Closing cap over screw provided.

Also available with all system exposed internal parts in stainless steel. All parts are commercially cleaned for cryogenic service. Also available with BSP threads.

Note: also available in stainless steel and special construction for hi-purity service. Contact your sales representative.

Temperature rating: +150°F to -320°F (339K to 78K)
 Maximum initial pressure: 600 psi (42.18 kg/cm²)

REDUCED PRESSURE RANGES

Valve size		Maximum working ranges	
Inches	(mm)	psi	(kg/sq cm)
1/4 & 3/8	[8 & 10]	5-30	(0.35-2.11)
		15-65	(1.05-4.57)
		30-110	(2.11-7.73)
		75-200	(5.27-14.06)
		100-400*	(7.03-28.12*)
1/2	[15]	0-7	(0-0.49)
		5-70	(0.35-4.92)
		50-150	(3.52-10.55)
		50-250	(3.52-17.58)
		200-500	(14.06-35.16)
3/4	[20]	0-10	(0-0.70)
		5-75	(0.35-5.27)
		50-200	(3.52-14.06)
		100-600*	(7.03-42.18)
1	[25]	10-50	(0.70-3.52)
		50-200	(3.52-14.06)
		100-600*	(7.03-42.18)
1 1/4 & 1 1/2	[32 & 40]	5-15	(0.35-1.05)
		10-50	(0.70-3.52)
		30-75	(2.11-5.27)
		50-120	(3.52-8.44)
		75-150	(5.27-10.55)
		100-400*	(7.03-28.12)

* **Note:** higher ranges are attained by modifying standard valve and/or using a different pressure spring. Contact your sales representative.

DIMENSIONS

Size	Dimensions						Shipping weight		
	A		B		C		lbs	(kgs)	
inches	(mm)	inches	(mm)	inches	(mm)	inches	(mm)		
1/4	[8]	4	[101.60]	6 5/8	[168.28]	2 3/16	[55.55]	9	[4.05]
3/8	[10]	4	[101.60]	6 5/8	[168.28]	2 3/16	[55.55]	9	[4.05]
1/2	[15]	4 3/4	[120.65]	7 5/8	[193.68]	2 3/16	[58.72]	16	[7.20]
3/4	[20]	5 5/8	[142.88]	10	[254.00]	2 5/8	[66.68]	24	[10.80]
1	[25]	6 1/2	[165.10]	10 3/4	[273.05]	2 7/8	[73.03]	35	[15.75]
1 1/4	[32]	8	[203.20]	12 5/16	[312.74]	3 1/16	[90.49]	63	[28.35]
1 1/2	[40]	8	[203.20]	12 5/16	[312.74]	3 1/16	[90.49]	63	[28.35]

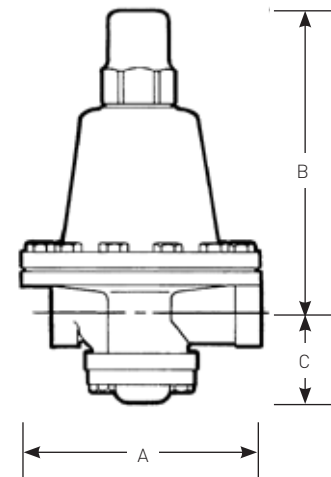

CASH VALVES CRYOGENIC VALVES AND CONTROLS

TYPE G60 SELECTION GUIDE

Example:	G60Z	A	W	S	S	Z	Z	B	S	01	-	E	0015
Model													
G60Z	G60 w/bronze body												
G60G	G60 w/316 stainless steel body												
Valve size													
A	1/4"			E	1"								
B	3/8"			F	1 1/4"								
C	1/2"			G	1 1/2"								
D	3/4"												
Service													
C	Cryogenic service												
F	Final line gas (O ₂ clean but not used in cryo service)												
Body/connection style													
S	Side inlet/side outlet - straight thru w/NPT connections												
Spring chamber style													
S	Standard												
C	w/pressure screw cap												
D	w/pressure screw cap and differential connection												
V	Vented												
W	Vented w/pressure screw cap												
Spring chamber material													
Z	Bronze												
G	316 stainless steel												
Diaphragm material													
B	NBR (final line gas)												
Z	Bronze (cryo)												
G	316 stainless steel (cryo)												
L	NBR w/PTFE liner (final line gas)												
Seat material													
B	NBR (final line gas)												
T	PTFE (cryo)												
V	FKM (final line gas)												
Pressure screw style													
S	Standard												
Variation													
01	Standard (303 stainless steel trim) (303 SST seat ring, 303 SST pusher post button, 303 SST pusher post, 303 SST guide bushing, 303 SST piston and 316 SST bottom cap)												
31	Brass trim (303 SST seat ring, brass pusher post button, brass pusher post, 303 SST guide bushing, brass piston and bronze bottom cap)												
Design revision													
(-)	Indicates original design												
Spring material													
E	Stainless steel												
Set pressure													
0005	5 psig												
0025	25 psig												
0300	300 psig												

Standard spring ranges - must specify during order process						
1/4" & 3/8" (**)	5-30	15-65	30-110	75-200	100-400	100-600
1/2" (**)	0-7	5-70	50-150	50-250	100-400	200-500
3/4" (**)	0-10	5-75	50-200	100-400	100-600	
1" (**)	10-50	50-200	100-400	100-600		
1 1/4" & 1 1/2" (**)	5-15	10-50	30-75	50-120	75-150	100-400

Note: (**) Stainless steel

CASH VALVES CRYOGENIC VALVES AND CONTROLS

E-55 PRESSURE REDUCING, PRESSURE BUILD-UP OR FINAL-LINE GAS SERVICE

Construction - for pressure reducing or pressure build-up service

Bronze body, spring chamber, trim; stainless steel body seat and pressure spring; PTFE seat, O-rings and bottom plug gasket; Monel® diaphragms and strainer screen; stainless steel bolts. All parts are commercially cleaned for cryogenic service. Also available with BSP threads.

Size range: 1/4", 1/2", 2" (32, 40, 50 mm)
 Temperature rating: +150°F to -320°F (339K to 78K)
 Maximum initial pressure: 400 psi (28.12 kg/cm²)

Construction - for final-line gas service

Bronze body, spring chamber and trim; stainless steel body seat and pressure spring; FKM seat disc and PTFE bottom plug gasket; FKM O-ring and neoprene diaphragm with FKM liner; Monel® strainer screen. All parts are commercially cleaned for oxygen service. Also available with BSP threads.

Size range: 1/2", 3/4", 1", 1 1/4", 1 1/2", 2" (15, 20, 25, 32, 40, 50 mm)
 Temperature rating: +150°F to 0°F (339K to 255K)
 Maximum initial pressure: 400 psi (28.12 kg/cm²)

Note: Specification for final-line gas service is not for use on cold gas or liquid (less than 0°F).

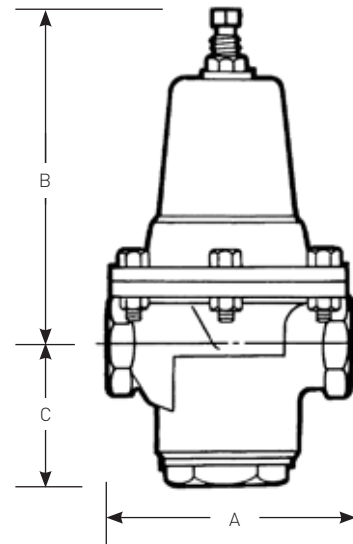

REDUCED PRESSURE RANGES

Valve size		Maximum working ranges	
Inches	(mm)	psi	(kg/sq cm)
1/2", 3/4", 1"	(15, 20, 25)	10-35	(0.70-2.46)
		20-75	(1.41-5.27)
		75-125	(5.27-8.79)
		125-175	(8.79-12.30)
		75-250	(5.27-17.58)
1 1/4", 1 1/2", 2"	(32, 40, 50)	20-70	(1.41-4.92)
		50-150	(3.52-10.55)
		75-300	(5.27-21.09)

DIMENSIONS

Size		Dimensions						Shipping weight	
		A		B		C			
inches	(mm)	inches	(mm)	inches	(mm)	inches	(mm)	lbs	(kgs)
1/2	(15)	4	(101.6)	7 1/4	(184.15)	2 1/4	(57.15)	6	(2.7)
3/4	(20)	4	(101.6)	7 1/4	(184.15)	2 1/4	(57.15)	6	(2.7)
1	(25)	4	(101.6)	7 1/4	(184.15)	2 1/4	(57.15)	6	(2.7)
1 1/4	(32)	5 5/8	(142.88)	11 1/8	(282.58)	3 1/4	(82.55)	17	(7.7)
1 1/2	(40)	5 5/8	(142.88)	11 1/8	(282.58)	3 1/4	(82.55)	17	(7.7)
2	(50)	5 3/4	(146.05)	11 3/8	(288.93)	2 7/8	(73.03)	17	(7.7)

CASH VALVES CRYOGENIC VALVES AND CONTROLS

TYPE E-55 SELECTION GUIDE

Example:	E55	C	C	S	G	T	01	-	E	0025
Model										
E55	E-55 valve w/bronze body and spring chamber									
Valve size										
C	1/2"	F	1 1/4"							
D	3/4"	G	1 1/2"							
E	1"	H	2"							
Service										
C	Cryo (1 1/4" - 2")									
F	Final line gas (all sizes)									
Body style/connection style										
S	Side inlet/side outlet - straight thru w/NPT connections									
B	Side inlet/side outlet - straight thru w/BSPT connections									
C	Side inlet/side outlet - straight thru w/NPT connections (enlarged port) 1" E-55 only									
D	Side inlet/side outlet - straight thru w/BSPT connections (enlarged port) 1" E-55 only									
Diaphragm material										
G	316 SST (cryo) (1 1/4" - 2")									
N	Neoprene w/FKM diaphragm liner (final gas line)									
Seat material										
T	PTFE (cryo)									
V	FKM (final line gas)									
Variation										
01	Standard									
Design revision										
(-)	Indicates original design									
Spring material										
E	SST									
Set pressure										
0005	5 psig									
0025	25 psig									
0150	150 psig									

Standard spring ranges - must specify during order process					
Sizes C, D, E (**)	10-35	20-75	75-125	125-175	75-250
Sizes F, G, H (**)	20-70	50-150	75-175	75-200	150-300

Note: (**) Stainless steel

CASH VALVES CRYOGENIC VALVES AND CONTROLS

THE ECONOMIZER CIRCUIT

The economizer back pressure regulator is set from 10 to 25 psi (.70 to 1.76 kg/sq cm) above the set pressure of the pressure build-up regulator. When no gas is being used and heat leakage in the tank causes a gas pressure build-up, the excess pressure is by-passed into the final vaporizer line to conserve gas rather than allow the safety valve in the pressure build-up circuit to relieve the excess gas into the atmosphere.

Five types of back pressure valves are available for this circuit: the Type FRM, low flows, max. 600 psi (42.18 kg/cm²); FRM-2, medium flows, max. 250 psi (17.58 kg/cm²); FRM-2 (HP) high pressure, medium flows, max. 400 psi (28.12 kg/cm²); FR, large flows, max. 400 psi (28.12 kg/cm²) and the FR-6, max. 600 psi (42.18 kg/cm²).

FRM BACK PRESSURE OR ECONOMIZER SERVICE

Construction

Threaded ends; 2-way, side inlet-side outlet; 2-way, side inlet-bottom outlet; 3-way, 2 side inlets-bottom outlet; forged bronze body; bronze diaphragms; stainless steel seat disc, seat ring and pressure spring; PTFE diaphragm gasket. All parts commercially cleaned for cryogenic service.

Note: Also available in stainless steel and special construction for hi-purity service. Contact your sales representative.

Temperature rating: +150°F to -320°F (339K to 78K)
 Maximum set pressure: 600 psi (42.18 kg/cm²)

PRESSURE RANGES

Maximum working ranges	
psi	(kg/sq cm)
2-25	(0.14-1.76)
15-65	(1.05-4.57)
40-100	(2.81-7.03)
75-175	(5.27-12.30)
100-250	(7.03-17.58)
200-400	(14.06-28.12)
300-600	(21.09-42.18)

DIMENSIONS

Description	Size		Shipping weight	
	inches	(mm)	lbs	(kgs)
Side inlet, side outlet	1/4	(8)	1 1/8	(0.51)
Side inlet, side outlet	3/8	(10)	1 1/8	(0.51)
Side inlet, bottom outlet	1/4	(8)	1 1/8	(0.51)
Side inlet, bottom outlet	3/8	(10)	1 1/8	(0.51)
2 Side inlets, bottom outlet	1/4	(8)	1 1/8	(0.51)

* Use valve numbers for pressures to 175 psi only. Consult factory for other numbers.

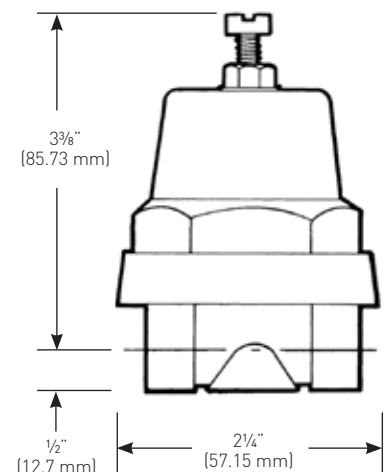

CASH VALVES CRYOGENIC VALVES AND CONTROLS

FRM-2, FRM-2 (HP) BACK PRESSURE OR ECONOMIZER SERVICE

Construction

Threaded ends; 2-way, side inlet-side outlet; 2-way, side inlet-bottom outlet; 3-way, 2 side inlets-bottom outlet; forged bronze body; cast bronze spring chamber; stainless steel seat disc, seat ring and pressure spring; bronze diaphragms; PTFE diaphragm gasket. All parts commercially cleaned for cryogenic service.

Note: FRM-2 available in stainless steel and special construction for hi-purity service. Contact your sales representative.

Temperature rating: +150°F to -320°F (339K to 78K)
 Maximum set pressure
 FRM-2: 250 psi (17.58 kg/cm²)
 FRM-2HP: 400 psi (28.12 kg/cm²)



PRESSURE RANGES

Size	Maximum working ranges	
	psi	(kg/sq cm)
FRM-2		
All sizes	0-30	(0-2.11)
All sizes	20-50	(1.41-3.52)
All sizes	40-80	(2.81-5.62)
All sizes	75-150	(5.27-10.55)
All sizes	100-275	(7.03-19.34)
FRM-2HP		
All sizes	200-400	(14.06-28.12)

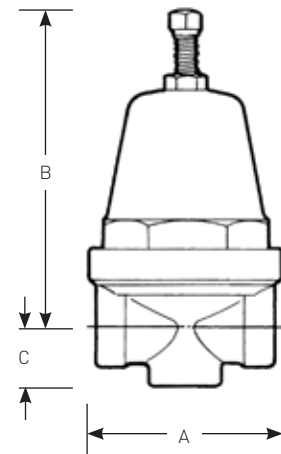

DIMENSIONS

Description	Size		Dimensions						Shipping weight	
	inches	(mm)	A		B		C		lbs	(kgs)
FRM-2										
Side inlet, side outlet	¼	(8)	2 ¹¹ / ₁₆	(68.26)	4½	(114.3)	¾	(19.05)	2½	(1.13)
Side inlet, side outlet	¾	(10)	2 ¹¹ / ₁₆	(68.26)	4½	(114.3)	¾	(19.05)	2½	(1.13)
Side inlet, side outlet	½	(15)	2 ⁷ / ₈	(73.03)	4½	(114.3)	1 ¹ / ₈	(28.58)	3½	(1.58)
Side inlet, bottom outlet	¼	(8)	2 ¹¹ / ₁₆	(68.26)	4½	(114.3)	¾	(19.05)	2½	(1.13)
Side inlet, bottom outlet	¾	(10)	2 ¹¹ / ₁₆	(68.26)	4½	(114.3)	¾	(19.05)	2½	(1.13)
Side inlet, bottom outlet	½	(15)	2 ⁷ / ₈	(73.03)	4½	(114.3)	1 ¹ / ₈	(28.58)	3½	(1.58)
2 Side inlets, bottom outlet	¼	(8)	2 ¹¹ / ₁₆	(68.26)	4½	(114.3)	¾	(19.05)	2½	(1.13)
2 Side inlets, bottom outlet	¾	(10)	2 ¹¹ / ₁₆	(68.26)	4½	(114.3)	¾	(19.05)	2½	(1.13)
2 Side inlets, bottom outlet	½	(15)	2 ⁷ / ₈	(73.03)	4½	(114.3)	1 ¹ / ₈	(28.58)	3½	(1.58)
FRM-2HP										
Side inlet, side outlet	¼	(8)	2 ¹¹ / ₁₆	(68.26)	4½	(114.3)	²⁵ / ₃₂	(19.84)	2½	(1.13)
Side inlet, bottom outlet	¼	(8)	2 ¹¹ / ₁₆	(68.26)	4½	(114.3)	²⁵ / ₃₂	(19.84)	2½	(1.13)
Side inlet, side outlet	¾	(10)	2 ¹¹ / ₁₆	(68.26)	4½	(114.3)	²⁵ / ₃₂	(19.84)	2½	(1.13)
Side inlet, bottom outlet	¾	(10)	2 ¹¹ / ₁₆	(68.26)	4½	(114.3)	²⁵ / ₃₂	(19.84)	2½	(1.13)
Side inlet, side outlet	½	(15)	2 ¹¹ / ₁₆	(68.26)	4½	(114.3)	1 ¹ / ₈	(28.58)	3½	(1.58)
Side inlet, bottom outlet	½	(15)	2 ¹¹ / ₁₆	(68.26)	4½	(114.3)	²⁵ / ₃₂	(19.84)	3½	(1.58)

CASH VALVES CRYOGENIC VALVES AND CONTROLS

FRM, FRM-2 SELECTION GUIDE

Example:	FRM-	A	W	Z	S	A	S	B	F	02	-	D	0005
Model													
FRM-	FRM												
FRM2	FRM-2												
Size													
A	1/4" (all)												
B	3/8" (all)												
C	1/2" (FRM-2)												
Service													
C	Cryogenic (FRM & FRM-2)												
Material of construction													
Z	Brass												
G	316 SST (FRM & FRM-2)												
E	303 SST (FRM)												
Body/connection style													
S	Side inlet/side outlet (all) NPT												
R	2 side inlets/bottom outlet (FRM & FRM-2) NPT												
E	Side inlet/bottom outlet (FRM & FRM-2) NPT												
B	Side inlet/side outlet (BSPT)												
P	Side inlet/side outlet 1/4" NPS - .082 wall pipe (FRM-2)												
T	Side inlet/side outlet 3/8" NPS - .035 wall pipe (FRM-2)												
V	Side inlet/side outlet 1/2" NPS - .049 wall pipe (FRM-2)												
Spring chamber material													
Z	Brass spring chamber												
G	SST spring chamber (FRM-2)												
C	Chrome plated												
Spring chamber style													
S	Standard												
W	Without vent hole												
Diaphragm material													
G	316 SST												
Z	Bronze												
Pressure screw style													
F	Fillister (FRM only)												
H	Hex												
T	T-handle (FRM)												
Variations													
03	303 Stainless steel trim w/PTFE diaphragm gasket (metal diaphragms only)												
04	303 Stainless steel trim w/6 x 0.005 thick bronze diaphragms												
05	303 Stainless steel trim w/nylon inserted locknut												
13	316 Stainless steel trim w/PTFE diaphragm gasket (metal diaphragms only)												
23	Monel trim w/PTFE diaphragm gasket (metal diaphragms only)												
32	Remote sensing												
Design revision													
(-)	Original design												
Spring material													
E	Stainless steel (FRM-2)												
Set pressure													
0005	5 psig												
0015	15 psig												
0100	100 psig												

Standard spring ranges - must specify during order process									
FRM (**)	2-25	15-65	40-100	50-150	75-175	100-250	200-400	200-600	300-600
FRM-2 (**)	0-30	20-50	40-80	75-150	100-275	200-400	300-600		

Note: (**) Stainless steel only

CASH VALVES CRYOGENIC VALVES AND CONTROLS

FR, FR-6 BACK PRESSURE OR ECONOMIZER SERVICE

Construction

Threaded ends; 3-way, 2 side inlets-bottom outlet; bronze body, spring chamber and diaphragms; brass body seat; stainless steel seat disc, seat ring and pressure spring; PTFE O-ring and diaphragm gasket; stainless steel bolts; pressure-tight closing cap. All parts are commercially cleaned for cryogenic service. Also available with BSP threads.

Note: also available in stainless steel and special construction for hi-purity systems. Contact your sales representative.

Temperature rating: +150°F to -320°F (339K to 78K)



MAXIMUM INITIAL PRESSURE

Type	psi	kg/cm ²
FR	250	17.58
FR-1/2"	400	28.12
FR-3/4"	265	18.64
FR-1"-2"	250	17.58
FR-6	400	28.12
2	600	42.18 on 1/2"

Maximum set pressure: see below. For higher pressures, contact your sales representative.

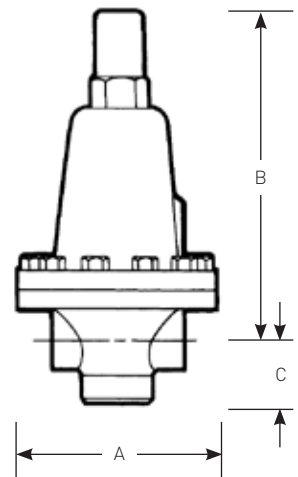

DIMENSIONS

Size in. (mm)	Dimensions						Shipping weight	
	A		B		C		lbs	(kgs)
1/2 (15)	4 3/4 (120.65)	6 3/4 (171.45)	1 5/8 (41.28)	9 1/2 (4.27)				
3/4 (20)	5 5/8 (142.88)	8 (203.20)	2 (50.80)	14 3/4 (6.64)				
1 (25)	6 1/2 (165.1)	10 5/16 (261.94)	2 1/4 (57.15)	23 1/2 (10.58)				
1 1/4 (32)	6 1/2 (165.1)	10 7/8 (276.23)	2 3/8 (60.33)	24 1/2 (11.03)				
1 1/2 (40)	7 1/2 (190.5)	10 3/4 (273.05)	2 5/8 (66.68)	33 (14.85)				
2 (50)	7 1/2 (190.5)	11 (279.40)	2 5/8 (66.68)	35 1/2 (15.98)				

PRESSURE RANGES

Valve size inches (mm)	Maximum working ranges		Valve size inches (mm)	Maximum working ranges	
	psi	(kg/sq cm)		psi	(kg/sq cm)
1/2 (15)	0-20	(0-1.41)	1 1/4 (15)	0-15	(0-1.06)
	10-50	(0.70-3.52)		20-85	(1.41-5.98)
	40-90	(2.81-6.33)		40-125	(2.81-8.79)
	75-200	(5.27-14.06)		50-250	(3.52-17.58)
	100-400	(7.03-28.12)		200-400*	(14.06-28.12)*
3/4 (20)	300-600	(21.09-42.18)	1 1/2 (40)	0-15	(0-1.06)
	0-10	(0-.70)		10-55	(0.70-3.87)
	10-70	(0.70-4.92)		30-100	(2.11-7.03)
	50-175	(3.52-12.30)		40-160	(2.81-11.25)
	100-265	(7.03-18.63)		100-250	(7.03-17.58)
1 (25)	200-400*	(14.06-28.12)*	2 (50)	200-400*	(14.06-28.12)*
	0-15	(0-1.06)		0-15	(0-1.06)
	20-75	(1.41-5.27)		10-55	(0.70-3.87)
	40-200	(2.81-14.06)		30-100	(2.11-7.03)
	50-250	(3.51-17.58)		40-160	(2.81-11.25)
200-400*	(14.06-28.12)*	100-250	(7.03-17.58)		
			200-400*	(14.06-28.12)*	

* Note: requires special diaphragm ring and pressure plate.

CASH VALVES CRYOGENIC VALVES AND CONTROLS

FR SERIES SELECTION GUIDE

Example	FR-	Z	A	W	S	S	Z	Z	B	H	01	-	E	0015
Model														
FR-	FR													
FR6	FR-6													
Material of construction														
Z	Bronze (FR, FR-6)													
G	316 SST (FR, FR-6)													
Valve size														
C	1/2"													
D	3/4"													
E	1"													
F	1 1/4"													
G	1 1/2"													
H	2"													
Service														
C	Cryogenic service													
Body/connection style														
S	2 side inlets/bottom outlet - w/NPT connections													
Spring chamber style														
S	Standard													
C	w/pressure screw cap													
D	w/differential connection													
V	Vented													
W	Vented w/pressure screw cap													
Spring chamber material														
Z	Bronze													
G	316 Stainless steel													
Diaphragm material														
Z	Bronze (cryo)													
G	316 Stainless steel (cryo)													
Body seat material														
E	303 Stainless steel													
G	316 Stainless steel													
Z	Brass													
Pressure screw style														
S	Standard													
Variation	(Trim consists of ball seat and seat ring)													
04	303 Stainless steel trim w/PTFE O-ring and PTFE diaphragm gasket													
14	316 Stainless steel trim w/PTFE O-ring and PTFE diaphragm gasket													
Design revision														
(-)	Indicates original design													
Spring material														
E	Stainless steel													
Set pressure														
0005	5 psig													
0025	25 psig													
0300	300 psig													

Standard spring ranges - must specify during order process						
FR 1/2" (**)	0-20	10-50	40-90	75-200	100-300	100-400
FR 3/4" (**)	0-10	0-15	10-70	50-175	100-265	
FR 1" (**)	0-15	10-35	20-75	40-200	50-250	
FR 1 1/4" (**)	0-15	10-30	20-85	40-125	50-250	
FR 1 1/2" & 2" (**)	0-15	5-20	10-55	30-100	40-160	100-250

Note: (**) Stainless steel

CASH VALVES CRYOGENIC VALVES AND CONTROLS

COMBINATION PRESSURE BUILDER-ECONOMIZER

PBE Series regulators combine the pressure building and economizer functions into one unit. The economizer phase starts at the point at which the pressure build level is reached, assuring a smooth transition between the two functions. For sizing information, please request engineering data sheets 1074 (PBE-1A) and 1077 (PBE-2).

PBE-1A COMBINATION PRESSURE BUILDER-ECONOMIZER

Construction

Forged brass body and spring chamber; brass and stainless steel trim; PTFE/Armalon or bronze diaphragm; stainless steel pressure spring. All parts are commercially cleaned for oxygen service.

Temperature rating: +150°F to -320°F
(339K to 78K)
Maximum initial pressure: 600 psi
(42.18 kg/cm²)

PRESSURE RANGES

Max. working pressure	
psi	(kg/sq cm)
50-175	(3.52-12.32)
150-350	(10.55-24.61)



DIMENSIONS

Size	Dimensions						Shipping weight		
	inches	(mm)	A		B		C		
1/4	(8)	2 1/4	(57.15)	3 1/8	(79.38)	7/8	(22.29)	1.4	(0.65)

Low pressure - ranges to 175 psig
High pressure - ranges 150-350 psig

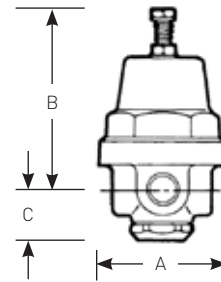

PBE-2 COMBINATION PRESSURE BUILDER-ECONOMIZER

Construction

Bronze body, spring chamber, trim and diaphragms; PTFE seat and diaphragm gasket; stainless steel economizer seat; stainless steel spring, nuts and bolts. All parts are commercially cleaned for oxygen service.

Temperature rating: +150°F to -320°F
(339K to 78K)
Maximum initial pressure: 400 psi
(28.12 kg/cm²)

PRESSURE RANGES

Max. working pressure	
psi	(kg/sq cm)
10-30	(0.70-2.11)
20-75	(1.41-5.27)
25-125	(1.76-8.79)
100-200	(7.03-14.06)
150-250	(10.55-17.58)



DIMENSIONS

Size	Dimensions						Shipping weight		
	inches	(mm)	A		B		C		
1/2	(15)	4 1/2	(114.30)	5 1/4	(133.35)	3	(76.20)	9	(4.08)

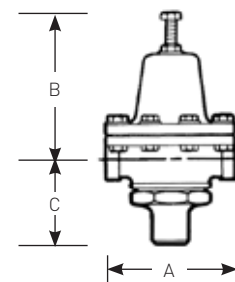

CASH VALVES CRYOGENIC VALVES AND CONTROLS

PBE-5 COMBINATION PRESSURE BUILDER-ECONOMIZER

Construction

Forged brass body, bronze spring chamber; brass and stainless steel trim; bronze diaphragms; stainless steel pressure spring; graduated adjustment screw. All parts are commercially cleaned for oxygen service.

Temperature rating: +150°F to -320°F
(339K to 78K)

Maximum initial pressure: 650 psi
(45.7 kg/cm²)

PRESSURE RANGES

Max. working pressure	
psi	(kg/sq cm)
0 - 30	(0.00 - 2.11)
20 - 50	(1.41 - 3.52)
40 - 80	(2.81 - 5.62)
75 - 150	(5.27 - 10.55)
100 - 275	(70.3 - 17.58)
200 - 350	(14.06 - 24.61)
300 - 600	(21.09 - 42.18)

DIMENSIONS

Size	Dimensions						Shipping weight	
	A		B		C			
inches (mm)	inches (mm)	inches (mm)	inches (mm)	inches (mm)	inches (mm)	lbs (kg)	kg (lbs)	
NPTF								
1/2 (15)	5.19 (131.8)	5.23 (132.9)	2.76 (70.2)	7 (3.2)				
1/2 (15)	5.19 (131.8)	5.23 (132.9)	2.76 (70.2)	7 (3.2)				

Note: 300 to 600 psi range, high pressure
Ranges to 350 psi, low pressure

Bullnose		Dimensions						Shipping weight	
		A		B		C			
inches (mm)	inches (mm)	inches (mm)	inches (mm)	inches (mm)	inches (mm)	inches (mm)	inches (mm)	lbs (kg)	kg (lbs)
0.839 (21.3)	9.81 (149.2)	5.13 (130.3)	4.48 (113.8)	8 (3.6)					
0.839 (21.3)	9.81 (149.2)	5.13 (130.3)	4.48 (113.8)	8 (3.6)					

Note: 300-600 psi range, high pressure
Ranges to 350 psi, low pressure

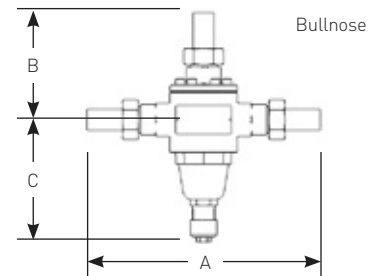
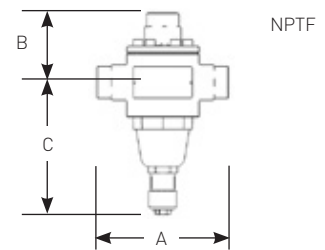

CASH VALVES CRYOGENIC VALVES AND CONTROLS

TYPES PBE-1, PBE-2, PBE-5 SELECTION GUIDE

Example:	PBE1	A	Z	3	S	01	-	E	0015
Model									
PBE1	PBE-1A valve								
PBE2	PBE-2 valve								
PBE5	PBE-5 valve								
Valve size									
A	1/4" (PBE-1A)								
C	1/2" (PBE-2; PBE-5)								
Body and spring chamber									
Z	Brass/bronze (all)								
G	316 SST (PBE-2)								
Economizer outlet side (see diagram below)									
2	Left hand (PBE-1A)								
3	Right hand; PB out l/h (PBE-1A)								
4	Right hand (PBE-1A)								
B	Bottom (PBE-2; PBE-5)								
Option									
S	Standard								
C	with check (PBE-2; PBE-5)								
Variation									
01	Standard								
02	With tube end connections (PBE-2; PBE-5)								
Design revision									
(-)	Indicates original design (PBE-2; PBE-5)								
B	With active economizer (PBE-1A)								
Spring material									
E	Stainless steel								
Set pressure									
0005	5 psig								
0025	25 psig								
0300	300 psig								

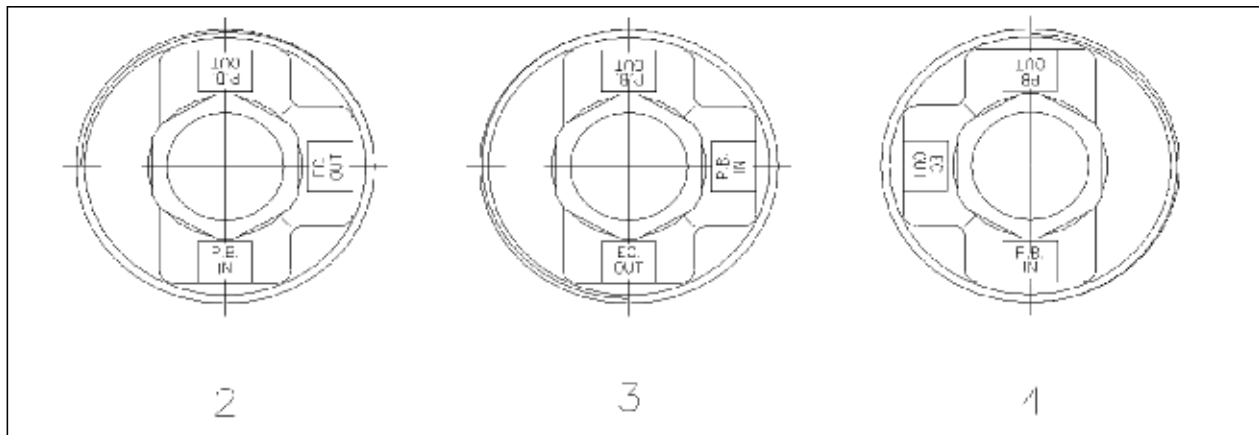

Standard spring ranges - must specify during order process							
PBE-1	15-65	50-175	150-350	300-600			
PBE-2	10-30	20-75	25-125	100-200	150-250	200-400	
PBE-5	0-30	20-50	40-80	75-150	100-275	200-350	300-600

CASH VALVES CRYOGENIC VALVES AND CONTROLS

LOW TEMPERATURE CUT-OFF VALVES

The temperature control valve between the vaporizer and service line regulator is designed to shut off the gas flow if the gas temperature drops below a pre-determined point, usually -20°F (144.4K), often caused by a rapid or quick gas draw. If the temperature drops below the temperature control valve's setting, the valve closes to prevent excessively cold gas from reaching the service end of the system. In particular, the cold gas is prevented from contacting the final-line regulator, which is not constructed or intended for such low-temperature conditions. The valve opens automatically when gas temperature rises above the set point.

The Type LTC temperature control valve is a double-port valve with a range of 0°F to -40°F (255K to 233K) for low temperature cut-off. As it is subject to ambient temperature under normal conditions, it will normally be in a wide-open position. A copper well is recommended for each installation, which allows the removal of the capillary bulb without depressurizing the system.

Note: valve seat closure may take several seconds under normal operating conditions. In addition, Type LTC fails in the closed position.



LTC REVERSE-ACTING TEMPERATURE REGULATOR FOR CRYOGENIC SERVICE

Construction

Brass union ends; bronze body and trim; copper capillary armor and bellows; PTFE gasket and packing; stainless steel spring; copper bulb and capillary.
Copper bulb is 1/2" x 5.82" (15 mm x 147.83 mm). All parts are commercially cleaned for oxygen service. A copper well is available as an option and is recommended for each cryogenic application.

Maximum operating limits

Operating temperature range is 0°F to -40°F (255K to 233K); standard setting is -20°F (244K).
Maximum temperature limit is 300°F (408K); minimum temperature limit is -320°F (78K).
Maximum body pressure on all sizes is 400 psi (28.12 kg/cm²); however, for proper operation, maximum pressure differentials as shown on page 21 must be observed.

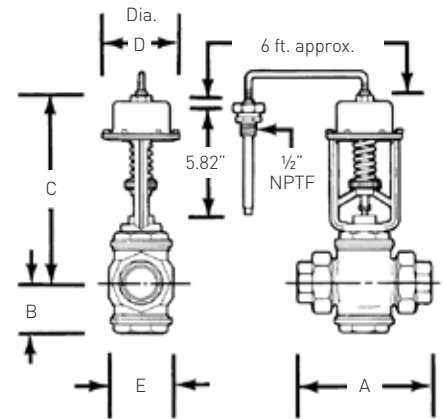

DIMENSIONS

Size		Dimensions									
		A		B		C		D		E	
in.	(mm)	in.	(mm)	in.	(mm)	in.	(mm)	in.	(mm)	in.	(mm)
1/2	(15)	6.04	(153.42)	2.08	(52.84)	9.80	(248.92)	4.31	(109.48)	2.50	(63.50)
3/4	(20)	6.04	(153.42)	2.08	(52.84)	9.80	(248.92)	4.31	(109.48)	2.50	(63.50)
1	(25)	6.04	(153.42)	2.08	(52.84)	9.80	(248.92)	4.31	(109.48)	2.50	(63.50)
1 1/4	(32)	7.61	(193.30)	2.75	(69.85)	10.47	(265.94)	4.31	(109.48)	3.56	(90.43)
1 1/2	(40)	7.61	(193.30)	2.75	(69.85)	10.47	(265.94)	4.31	(109.48)	3.56	(90.43)
2	(50)	8.58	(217.43)	3.12	(79.25)	10.84	(275.34)	4.31	(109.48)	4.31	(109.48)

Note: also available: Separable well - ask for part number 17960.
Thermal system repair kit - ask for part number 18052.

CASH VALVES CRYOGENIC VALVES AND CONTROLS

TYPE LTC MAXIMUM PRESSURE DIFFERENTIALS

Valve size		Temperature setting					
		0°F	(255°K)	-20°F	(244.4°K)	-40°F	(233°K)
inches	(mm)	psi	(kg/sq cm)	psi	(kg/sq cm)	psi	(kg/sq cm)
1/2 - 3/4	(15-20)	400	(28.12)	400	(28.12)	400	(28.12)
1	(25)	275	(19.23)	400	(28.12)	400	(28.12)
1 1/4 - 1 1/2	(32-40)	275	(19.23)	350	(24.61)	350	(24.61)
2	(50)	275	(19.23)	275	(19.23)	300	(21.09)

Note: it requires approximately 15°F change in temperature to fully close valve.

TYPE LTC CAPACITY INFORMATION (SCFH) OXYGEN SERVICE - 50 PSI AND 100 PSI LEVELS

Size	C _v	50 psi level				100 psi level			
		1 psid	2 psid	5 psid	10 psid	1 psid	2 psid	5 psid	10 psid
1/2"	9.0	4109	5788	9044	12530	5480	7734	12147	16986
3/4"	9.0	4109	5788	9044	12530	5480	7734	12147	16986
1"	13.0	5935	8361	13064	18100	7916	11171	17546	24535
1 1/4"	37.5	17122	24119	37684	52211	22835	32223	50612	70775
1 1/2"	37.5	17122	24119	37684	52211	22835	32223	50612	70775
2"	52.5	23970	33767	52757	73095	31969	45113	70857	99085

TYPE LTC CAPACITY INFORMATION (SCFH) OXYGEN SERVICE - 150 PSI AND 200 PSI LEVELS

Size	C _v	150 psi level				200 psi level			
		1 psid	2 psid	5 psid	10 psid	1 psid	2 psid	5 psid	10 psid
1/2"	9.0	6572	9280	14605	20495	7506	10602	16705	23485
3/4"	9.0	6572	9280	14605	20495	7506	10602	16705	23485
1"	13.0	9492	13404	21096	29603	10842	15315	24129	33922
1 1/4"	37.5	27382	38665	60853	85394	31274	44177	69604	97853
1 1/2"	37.5	27382	38665	60853	85394	31274	44177	69604	97853
2"	52.5	38334	54130	85195	119552	43784	61847	97445	136994

Note: psid values are pressure drops across valve.

TO DETERMINE CAPACITY

Determine operating pressure level at the valve and the maximum allowable pressure drop across the valve. Then refer to table above reading down the appropriate column to the selected pipe size. As an example: you are operating at a 150 psi pressure level and the maximum allowable pressure drop across the valve is 2 psi. Look at the second table under the 150 psi level and 2 psid column. For a 1 1/4" pipe size, the capacity would be 38,665 SCFH. Note: the values shown in the table are for oxygen gas; all capacity figures are standard cubic feet per hour. To determine capacity figures for other gases, consult the conversion chart below and multiply the chart capacities by the factor given.

GAS CONVERSION FACTORS

Gas	Oxygen	Nitrogen	Hydrogen	Helium	Argon
Factor	1.000	1.075	4.000	2.860	0.893

TYPE LTC SELECTION GUIDE

Example:	LTC	C	S	-	01	A
Model						
LTC LTC valve						
Valve size						
C 1/2"						
D 3/4"						
E 1"						
F 1 1/4"						
G 1 1/2"						
H 2"						
Connection type						
S NPT threaded union ends						
B BSPT threaded union ends						
Design revision						
(-) Indicates original design						
Variation						
01 Catalog standard						
02 With Thermowell						
Temperature range						
A -40°F to 0°F						

CASH VALVES CRYOGENIC VALVES AND CONTROLS

FINAL LINE CIRCUIT (HOUSE LINE)

Liquid is forced into the vaporizer through the liquid line by the action of the vapor pressure in the tank. The liquid in the vaporizer is warmed by ambient air (or sometimes by steam) and changed into gas, which is then distributed through the final-line regulator. As the gas is at or near ambient temperature, the diaphragm and seat in the regulator can be furnished in standard rubber materials.

A-31 PRESSURE REDUCING VALVE FOR FINAL-LINE GAS SERVICE

Construction

Brass forged body, brass piston; NBR seat disc and diaphragm; aluminum spring chamber; stainless steel spring. All parts are commercially cleaned for oxygen service. Standard valve has side inlet-side outlet connections. Also available with side gauge connections.

Temperature rating: +150°F to 0°F [339K to 255K]
 Maximum initial pressure: 400 psi (28.12 kg/cm²)

REDUCED PRESSURE RANGES

Maximum working ranges	
psi	(kg/sq cm)
2-25	(0.14-1.76)
15-65	(1.05-4.57)
40-100	(2.81-7.03)
50-150	(3.52-10.55)
75-175	(5.27-12.30)

DIMENSIONS

Size		Dimensions						Shipping weight	
		A		B		C			
inches	(mm)	inches	(mm)	inches	(mm)	inches	(mm)	lbs	(kgs)
1/4	(8)	2 1/4	(57.15)	3 3/16	(80.96)	5/8	(15.88)	1 1/8	(0.51)

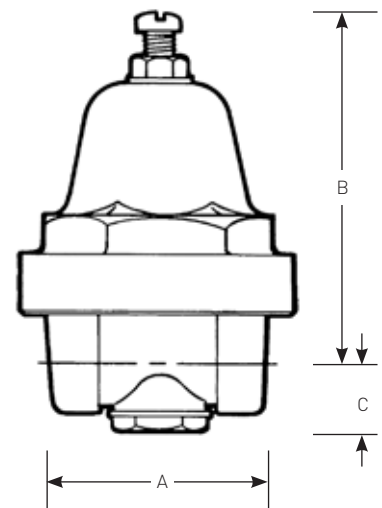

CASH VALVES CRYOGENIC VALVES AND CONTROLS

A16, A31, A31S, A31VR, A32, A32S SELECTION GUIDE

Example:	A16-	A	W	S	A	S	B	B	F	02	-	D	0005
Model													
A16-	A16												
		A32Z	A32 w/bronze body										
A31-	A31												
		A32E	A32 w/stainless steel body										
A31S	A31S												
		A32S	A32S										
A31V	A31VR												
Size													
Y 1/8"	(A31, A31S)												
A 1/4"	(A16, A31, A31S, A31VR, A32, A32S)												
B 3/8"	(A16, A31, A31S, A32)												
Service													
W	Water/air												
C	Cryogenic (A32Z, A32E)												
F	Final line gas (A31)												
V	Vacuum service (A32VR)												
Body/connection style													
S	Side inlet/side outlet - straight thru (A16, A31, A32)												
R	Side inlet/side outlet - straight thru w/right side gauge port (A31S)												
L	Side inlet/side outlet - straight thru w/left side gauge port (A16, A31S)												
B	Side inlet/bottom outlet w/straight thru gauge connection (A31VR)												
Spring chamber material													
A	Aluminum spring chamber (A16, A31, A31S, A32, A32S)												
Z	Brass spring chamber (A31, A32, A31VR only)												
C	Brass chrome plate spring chamber (A32 only)												
Spring chamber style													
S	Standard												
N	Non-vented												
P	Panel mount												
Diaphragm material													
B	NBR (A16, A31, A31S, A32S)						T Neoprene w/PTFE liner (A31, A31S)						
L	NBR w/ PTFE liner (A31, A31S)						Z Bronze (A32 only)						
G	316 SST (A32)						R EPR (A31VR, A32S)						
N	Neoprene (A31, A31S)						F EPR w/ PTFE liner (A31VR)						
Seat material													
B	NBR (A16, A31, A31S, A32S)						S Silicone (A31VR)						
T	PTFE (A31, A32, A32S)						K Kalrez (A31VR)						
V	FKM (A31, A31S)												
Pressure screw style													
F	Fillister (A16, A31, A31S, A32, A32S)						K Knurled (A31VR)						
T	T-handle (A31, A31S)						W Handwheel plastic (A21)						
H	Hex (A31, A31S, A32)												
Variations													
01	Standard						11 Standard variation w/inlet screen (A31, A32)						
02	Balanced piston (A31, A31S)						12 Balanced piston w/inlet screen (A31)						
Design revision													
(-)	Original design												
Spring material													
D	Carbon steel (Industrial or final line gas service only)												
E	Stainless steel												
Set pressure													
0005	5 psig												
0015	15 psig												
0100	100 psig												

Standard spring ranges - must specify during order process										
A16 (*)	2-30	10-50	25-90	80-120	100-180					
A31, A31S & A32 (*)	2-30	10-50	30-90	80-120	100-180					
A31 & A32 (**)	2-15	2-25	15-65	40-100	50-150	75-175	100-250	200-400 [A32]	300-600 [A32]	
A31S (**)	2-15									
A31VR (*) in/hg	0-15	10-30								

Note: (*) Steel (**) Stainless steel

CASH VALVES CRYOGENIC VALVES AND CONTROLS

HIGH PURITY REGULATING VALVES

A line of high purity regulating valves for electronic grade and other high purity gases is also available. This includes pressure reducing valves, back pressure valves and valves suitable for differential service.

Valve bodies are investment cast 316L stainless steel, with internal trim 316L bar stock. Interior (wetted) surface finish is 15 micro inch or better. The finish is electropolished. Also, all maintenance may be carried out without removing the valve from the line.

Sizes are 1/2" to 1 1/2", butt weld ends, 0.065 wall (1/2" size, 0.049 wall). Spring ranges are typically up to 400 psig (28.12 kg/cm²) control.

Temperature limits are 400°F [478K] to -425°F [19K]. All valves are cleaned for high purity gas compatibility.

Contact your sales representative for additional information and pricing.

Reference:

G60HP-pressure build service

FRHP-economizer service



C-776 SAFETY VALVE

Type C-776 cryogenic safety valves are available in sizes from 1/2" thru 2" (15 to 50 mm).

Request data sheet VCTDS-00515 for details.



2300 SHUT-OFF VALVE

Type 2300 is a brass shut-off globe style valve with 1/4", 3/8", and 1/2" (7, 10.5 and 15 mm) NPTF connections. It offers the option of a stainless steel stub end inlet connection with a 3/8" (10.5 mm) NPTF outlet connection.

Temperature rating: +150°F to -320°F [339K to 78K]

Maximum inlet pressure: 700 psig [49.2 kg/cm²]



CASH VALVES CRYOGENIC VALVES AND CONTROLS

TYPE 2300 SELECTION GUIDE

Example:	2300	A	S	P	-	01
Model						
2300	2300 shut-off valve					
Valve size						
A	1/4"					
B	3/8"					
C	1/2"					
Body connection						
S	Side in/side out w/NPT connections					
B	Side in/side out w/BSPP connections					
1	Inlet 3/8" sch.10 x 1.125 long pipe/outlet 3/8" NPT					
2	Inlet 3/8" sch.10 x 2.125 long pipe/outlet 3/8" NPT					
3	Inlet 3/8" sch.10 x 3.375 long pipe/outlet 3/8" NPT					
4	Inlet and outlet 3/8" sch.10 x 1.125 long pipe					
5	Inlet 1/2" sch.5S x 2.125 long pipe/outlet 1/2" NPT					
Handwheel colors						
P	Plain					
B	Blue					
G	Green					
R	Red					
Design revision						
(-)	Indicates original design					
Variation						
01	Standard					
02	With 4" extended stem					

CASH VALVES CRYOGENIC VALVES AND CONTROLS

SY-70C 'Y' PATTERN STRAINERS

These strainers are suited for most cryogenic applications. Installed in the line ahead of automatic regulators, they protect valve seats, gauges, meters, regulators and other equipment from most foreign material to reduce maintenance costs and replacement expense.

Construction

ASTM B62 high-tensile cast bronze body, 100 mesh Monel® strainer screen; a brass blowoff plug is shipped with each strainer. All parts are commercially cleaned for cryogenic service.

Temperature rating: +150°F to -320°F (339K to 78K)
 Maximum set pressure: 400 psi (28.12 kg/cm²)

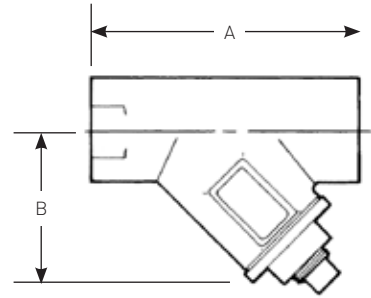

DIMENSIONS

Strainer size		Blow off plug size		Dimensions				Shipping weight	
				A		B			
inches	(mm)	inches	(mm)	inches	(mm)	inches	(mm)	lbs	(kgs)
1/2	[15]	1/4	[8]	2 ¹⁵ / ₁₆	[74.68]	1 ²⁷ / ₃₂	[46.99]	0.6	[0.27]
3/4	[20]	1/4	[8]	3 ⁹ / ₈	[91.95]	1 ¹⁵ / ₁₆	[49.53]	1.3	[0.59]
1	[25]	3/8	[10]	4 ¹ / ₂	[114.30]	2 ³ / ₄	[69.85]	2	[0.91]
1 1/4	[32]	3/8	[10]	5 ¹ / ₈	[130.30]	3 ¹¹ / ₃₂	[85.09]	3.1	[1.41]
1 1/2	[40]	1/2	[15]	5 ¹³ / ₁₆	[147.58]	3 ³ / ₄	[95.25]	4.1	[1.86]
2*	[50]	3/4	[20]	6 ¹³ / ₁₆	[172.58]	4 ¹³ / ₁₆	[122.68]	9	[4.08]

Capacity information

Capacity information is available on request. Write to the factory supplying full valve and application specifications.

NOTE

NPTF, also referred to as 'Dryseal' thread, is designed to provide a more leak-free seal without the use of PTFE tape or other sealant compound. NPTF threads are interchangeable with NPT threads and are standard on all Cash Valve products.



PENTAIR VALVES & CONTROLS

www.pentair.com/valves

All Pentair trademarks and logos are owned by Pentair plc. All other brand or product names are trademarks or registered marks of their respective owners. Because we are continuously improving our products and services, Pentair reserves the right to change product designs and specifications without notice. Pentair is an equal opportunity employer. © 2015 Pentair plc. All rights reserved.