

MV

SERIES

Description

The Series MV High Pressure Gas Control Valve is optimized for the demanding requirements of Gas Cylinder Fill Plants, Manifold, and Piping System applications. The High Pressure Oxygen Service Valve Configuration (Seal Option C) was third party tested per ISO 7291 (O2 Surge) and ASTM G175 (Promoted Ignition). The valve is also available with a PCTFE seal (Seal Option K) for positive sealing in non-oxygen applications. The Series MV is available in a variety of porting and mounting configurations. The panel mount configuration is supplied with two panel nuts for easy retro-fitting to existing panel mount installations.

Features

- **OXYGEN SAFE:** Copper Valve (Seal Option C) Configuration Third Party Tested per ISO 7291 (O2 Surge) and ASTM G175 (Promoted Ignition)
- **LOW TORQUE:** Needle Thrust Bearing Maintains Low Operating Torque (< 10 in-lbs) Throughout Full Pressure Range
- **FLOW CONTROL:** Unique Valve Geometry Allows User to Meter Flow on Initial Opening and Minimizes Initial Pressure Surges
- **LONG SERVICE LIFE:** Optimized Material and Component Selection for Long Service Life; Non-Rotating Poppet and Non-Rising Stem Maintain Seat and Seal Integrity, Needle Thrust Bearing Efficiently Minimizes Wear Effects of Mechanical Load
- **FAST OPENING:** 2.5 turns from Closed to Full-Open
- **HIGH FLOW:** Large Orifices and Internal Flow Paths for Maximum Flow Efficiency
- **FIELD RE-BUILDABLE:** All Seat / Seal Configurations Fully Field Re-Buildable
- **ADAPTABLE TO EXISTING INSTALLATIONS:** Panel mount version supplied with two panel nuts for easy retro-fitting to existing installations

Technical Data

- Operating Pressure Range: Vacuum to 5500 Psig (380 Bar) @ 70°F (MAWP Rating per ASME BPVC Section VIII Division 1)
Note: Valves with NPSM Connections (1" - 11.5 NPSM) are de-rated to 3500 Psig (242 bar) due to the connection's maximum pressure rating.
- Operating Temperature Range: -40° to 165°F (-40° to 74°C)
- Flow Coefficient: C_v is 2.5 for all valve configurations
- Valves are 100% Factory Tested for Internal and External Leakage
No bubbles visible for 10 seconds with N2 gas at 2500 PSI.

Materials of Construction

Component	Material	
	Copper Seat	PCTFE Seat
Body	CW617N Forged Brass, EN 12420	
Handle, Bonnet, Poppet, Panel Nut, Inner Bonnet, Washer	Brass, ASTM B16	
Needle Bearing, Bearing Washer (Both Non-Wetted)	ANSI 52100 Bearing Steel 58-62 HRc	
Stem Seal	FKM	Molythane
Poppet Insert (Seal)	Copper, ASTM B152	PCTFE, ASTM D1430
Replaceable Seat and Stem	Monel® 400	303 SS
O'Rings (2)	FKM	
Replaceable Seat Crush Washer	Copper, ASTM B152	
Seal Washer, Backup Rings (2)	PTFE, ASTM D1710	
Handle Nut and Washer	Zinc Plated Steel	

Valve is lubricated with Dupont Krytox®.
 Monel® is a registered trademark of Special Metals Corporation.



Model MV

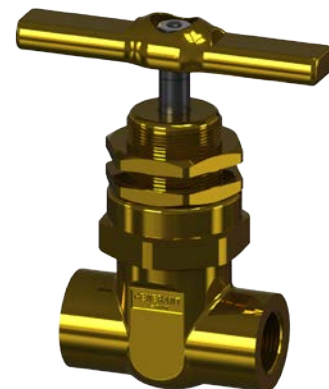

Model MVP

HIGH PRESSURE GAS CONTROL VALVE

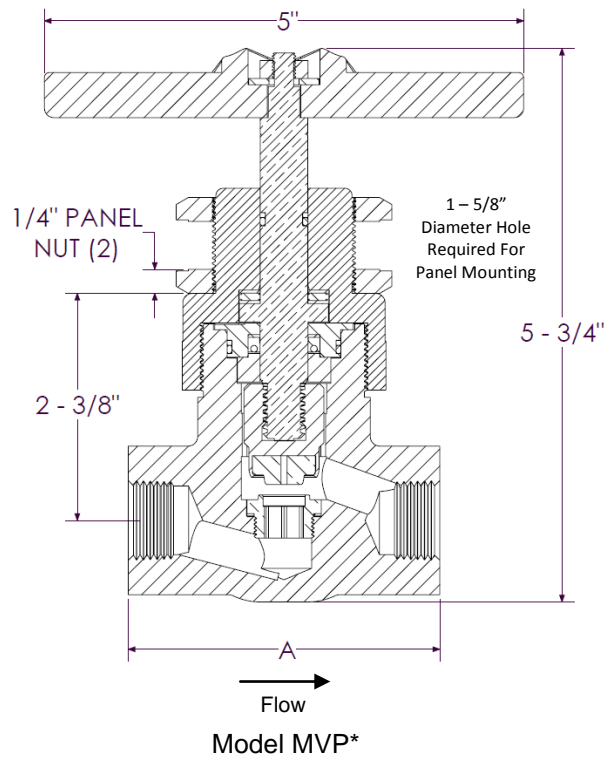
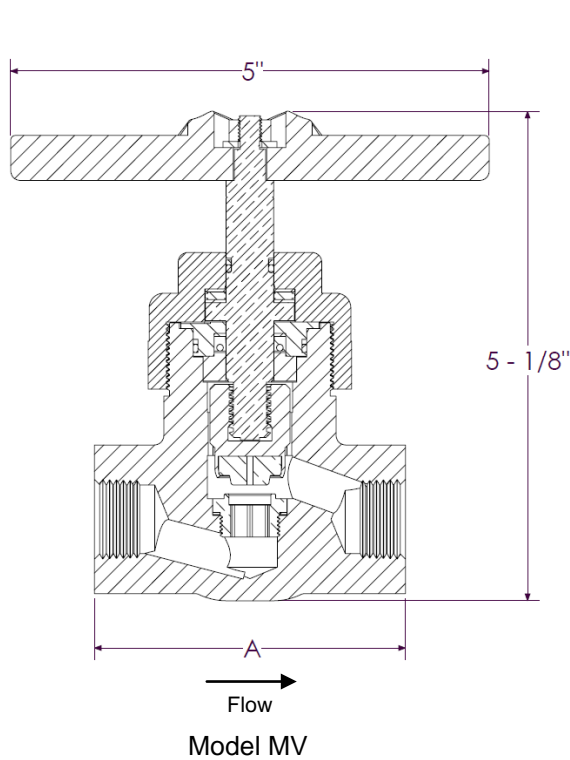

*Model MVP Valves are supplied with two panel nuts to allow for variable depth panel mounting (back of panel to port centerline: 2-3/8" to 3").

Dimensional Data

PORT SIZE	PORT CONFIGURATION	Dimensions: inches (millimeters)	
		Valve Orifice	Dimension A
4F	1/2" NPT Female	0.406 (10.3)	3.25 (82.5)
6F	3/4" NPT Female		
8NR	1" 11.5 NPSM Right Hand		3.80 (96.5)
8NL	1" 11.5 NPSM Left Hand		
2FS	1-3/8"-12 O'Ring Seal Union		

Notes: Dimensions are in inches (millimeters), for reference only and subject to change. Restrictions in inlet or outlet piping may reduce flow. NPT Threads per ASME B1.20.1.

How To Order

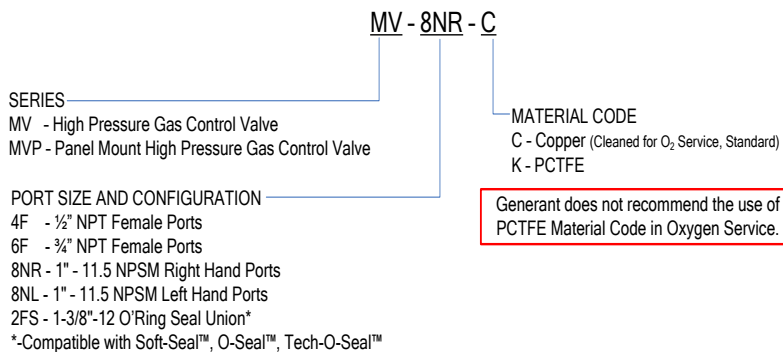

Repair Kits

Seal Material	Specify	Kit Includes
Copper (Cleaned for O ₂ Service, Standard)	MV-C	Copper Poppet Assembly, Replaceable Seat Insert, Replaceable Crush Washer, Needle Bearing and Bearing Washer (2), U-Cup Stem Seal, Teflon Backup Washer, O'rings (2) and Teflon Backup Rings(2)
PCTFE	MV-K	PCTFE Poppet Assembly, Replaceable Seat Insert, Replaceable Crush Washer, Needle Bearing and Bearing Washer (2), U-Cup Stem Seal, Teflon Backup Washer, O'rings (2) and Teflon Backup Rings(2)

PROPER COMPONENT SELECTION – When specifying a component, the total system design must be considered to ensure safe and trouble-free performance. Intended component function, materials compatibility, pressure ratings, installation, environment and maintenance are the responsibility of the system designer.



www.generant.com

1865 Route 23 South PO Box 768 Butler, New Jersey 07405 973.838.6500 Fax 973.838.4888